

You worked everybody on 144 MHz EME so try 432 MHz EME!

(Aka What is different on 432 MHz EME?)

*Geert Stams, PA3CSG, Ittervoortseweg 60, 6017 BZ Thorn, The Netherlands.
pa3csg@gmail.com*

1. Introduction

There have been some dramatic changes in the activity level on 70cm moonbounce over the last few years. The people active on that band have left and are now active on 1296 MHz or are not at all active on EME.

The digital modes have been responsible for some drastic changes on 144 MHz as well. Including a rather large activity by smaller stations and a lot of DX-pedition activity.

This paper is not to describe the good old days of 432 MHz EME nor is it to praise or disgust the new digital modes. This paper just wants to explain the differences in EME on the higher bands (432 and above) in comparison with EME on 144 MHz. Also the paper provides some basic information about things related to moonbounce like noise, aerial gain etc. The activity is growing on 432 MHz at this moment due to the fact that some stations have been 'playing' on 144 MHz for a long time and are now looking towards new challenges. This paper intends to be helpful in getting your station running on EME and to point you the mistakes many of us made and many of you will still make now until you correct things and really find out about the critical factors in EME communication.

There will be nothing spectacular new presented. All here described has been published before and is just a get together of old information in a new document.

This will not be a high tech story about EME but something all of us should be able to understand. With simple mathematics which can be done with a simple calculator. Just something to open your eyes. OK you don't want to do the math? There is plenty of software around to do the work for you!

2. The challenge

To make effectively EME contacts it is necessary that you are able to copy your own echoes. Whether you want to do that by computer or by ear is up to you. For me I never wanted to rely on the quality of the station I was working. The question is are you working W5UN or is he working you? These big guns are sure very helpful in getting going on a band and most of us worked them for their first contact.

If we look at the EME path loss for the different frequencies we easily see the difference:

<i>Frequency</i>	<i>Path loss at perigee</i>	<i>Path loss at apogee</i>
50 MHz	241,77dB	244,10dB
144 MHz	250,96dB	253,28dB
432 MHz	260,50dB	262,80dB
1296 MHz	270,04dB	272,37dB
2320 MHz	275,04dB	277,37dB

*Table 1. Data taken from the VK3UM EME performance calculator
(Perigee means moon is close to earth, apogee moon is on its most distant point from earth)*

Well things don't look as exactly hopeful do they? Is it better to stay on the lower frequencies as losses are significantly lower. Losses do increase with frequency. But antenna gain for the same size also increase.

3. The antenna

Without doubt the most important part of the EME-system is the antenna. Each one of us has to choose his antenna system with care. We must understand that a well optimised small EME system might do better than a badly build large system.

3.1 Electrical

Let us compare your 4 yagi station on 2 meters with a group of 4 yagis on 70 cm. We will look at gain figures and mechanical dimensions. For comparison reasons we will take antennas which are equally long.

Günther Hoch, DL6WU developed the following formula for yagi gain in the VHF / UHF region:

$$Gain = 9,2 + 3,39 \ln(\text{boomlength}(\lambda)) \quad (I)$$

This is only a approximation and not a exact calculation. More modern yagis will produce a higher gain and a lower antenna temperature.

Calculating gain for a 6,3M long (3,1λ antenna) on 144 MHz results in 13,1 dBd gain
 The same length will produce a gain of 16.6 dBd on 432 MHz. The shorter wavelength will partly compensate for the higher path losses as seen in chapter 2. Converting dBd to dBi one just has to add 2,15. Example: 13dBd will result in 13+2,15=15,15dBi

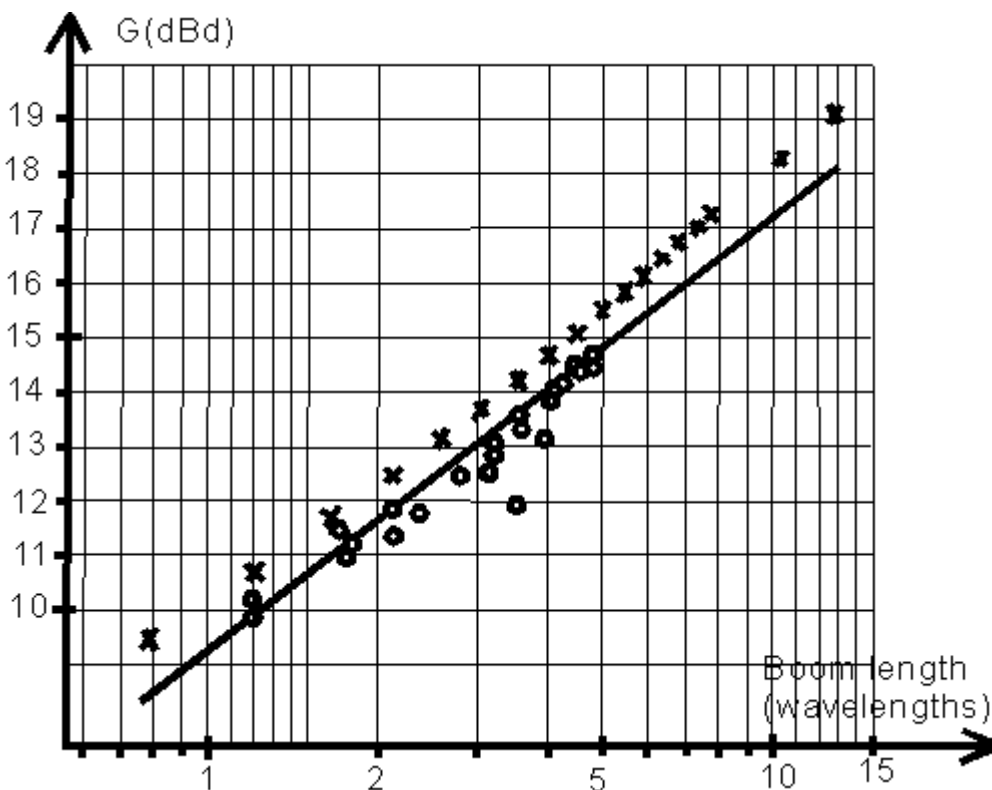

Graph taken from <http://www.nitehawk.com/sm5bsz/antennas/cpudes01.htm>

We are still lacking another 3 dB as the path loss on 144 MHz is 10 dB lower than on 432 MHz. Antenna gain also works on receive as well on transmit.

3.2 Mechanical

Higher frequencies result in smaller antennas. A group of four 9 lambda yagis is a 'box' of 1,8 x 1,8M x 6,3M. A group of yagis with the same length on 144 is something like 3,5M x 3,5M x 6,3M. Requiring less powerful rotators for azimuth and elevation. Also in very windy or icy areas a smaller group will easily survive. A group of 16 yagis on 432 MHz wouldn't be much bigger than a 4 yagi group on 144 MHz.

3.3 Dishes

On 1296 and above the most common antenna is the parabolic reflector with a feed in front of it. There are several reasons for this but the most important reason is that on 1296 MHz and above circular polarisation is used. Losses in phasing lines would be too big to accomplish this with yagis. By changing feeds one can switch bands. Multi feed arrangements are also in use. But you have to pay a penalty for that as feeds are not exactly in the focal point and feeds suffer from extra noise pick up especially on the higher bands. Sizes from 2.5M diameter and upwards are in use. The bigger the better.

A parabolic dish can also be used on 432 MHz, diameters from 5 meter and up are in successful use. Big advantage is the possibility to switch polarisation with 2 sets of dipoles.

Parabolic dishes look like the ideal antenna but these are rather difficult to make and it requires large rotators and towers. Another thing is the readout of large dishes. The accuracy of the readout has to be very precise. It is very time consuming to build one or very money consuming to buy one. But there are some commercial solutions available.

3.4 Matching

All modern yagis have been computer optimized for maximum gain on the frequency of operation. Leaving us with very narrow bandwidth and low impedance antenna. Some yagis are so critical that high SWR problems occur when more yagis are put into a group. The large bandwidth antennas prove to be less critical but produce less gain. Very precise building is advised for these highly tuned yagis.

3.5 Noise

Every antenna has a radiation pattern which is not perfect. Therefore it will not only 'look' in the direction it is pointing (normally the sky for EME communication) but will also 'see' a part of the very noisy environment (city) it is placed. It will pick up noise from the ground as well. A clean pattern is needed very much. In this respect Lionel VE7BQH provided us with his famous G/T table of 144 MHz yagis (reference 6). This list proved to be very useful over the years.

Not often taken into account is that there are also ohmic losses in yagis as well. Especially going up in frequency these will play a role as well. Some of the moonbouncers use copper enamelled wire to minimize these losses. This will increase the weight of the antenna and will not have the mechanical strength of aluminium tubing. Maybe more important it is to make sure that the elements have good contact with the boom IF these have to be connected to the boom. Günther Hoch, DL6WU, advised me years ago to mount the elements insulated from the boom to prevent these problems.

4. The power amplifier

Looking at frequencies from 50 MHz up to 2320 MHz one could say that with the exception of 2320 MHz it is possible to generate 1kW of RF with a tube amplifier or even with solid state amplifiers. Many of us prefer the ruggedness of the tube amplifier compared with the solid state amp. Other dislike the tubes because of their lethal voltages used. It might be a question of how much money you can (or want to) spent on those devices.

Many good designs are available for all bands using whatever tube that you can find. The surplus Russian tubes are certainly very popular because of their low price and availability. There are some surplus cavities around that generate large amounts of RF power on 1296 MHz. Again there are not much differences. It is a matter of what is within your reach.

On 2320 MHz there are some reliable 200-300W surplus solid state amplifiers available for low

prices.

One fact to take into account is that cable losses do get higher on the higher frequencies. Below you find a table stating the losses on the different frequencies for some of the cables used nowadays. You have to bring the power to your antenna. It might be easier to use a solid state amp at the feed or the base of the tower.

Type	50 MHz	144 MHz	432 MHz	1296 MHz	2320 MHz
RG58	9,1dB/100M	16,4dB/100M	31,0dB/100M	61,5dB/100M	90,7dB/100M
RG213	4,8dB/100M	8,5dB/100M	16,0dB/100M	31,6dB/100M	46,5dB/100M
Belden 9913	2,9dB/100M	5,1dB/100M	9,2dB/100M	17,0dB/100M	24,0dB/100M
LMR-600	1,8dB/100M	3,1dB/100M	5,5dB/100M	10,0dB/100M	13,9dB/100M
LDF4-50	1,5dB/100M	2,6dB/100M	4,7dB/100M	8,4dB/100M	11,6dB/100M
LDF5-50	0,8dB/100M	1,4dB/100M	2,6dB/100M	4,8dB/100M	6,6dB/100M

Table 2. RG58 and RG213 come from different manufacturers values may vary. These cables only to be used as dummy or attenuator.

5. Noise

5.1 General

Below follows a general discussion about noise and noise in amplifiers.

The most ideal amplifier would be an amplifier with gain (G) and without any noise contribution. In real life where nothing is perfect this cannot be true. This is why a noisy amplifier could be represented as below:

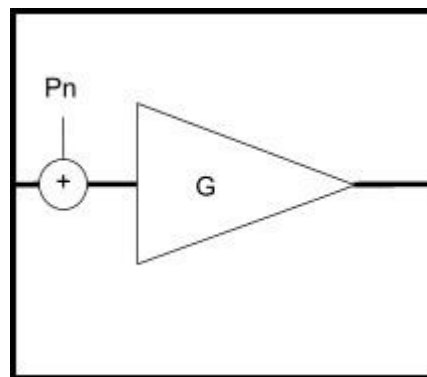

The ideal amplifier with a noise source at the input. For this amplifier one could state the following:

The noise factor F where $F > 1$

The noise figure $NF(dB) = 10 \log F$ (II)

The gain G $G(dB) = 10 \log G$ (III)

When we would connect a resistor at room temperature this resistor would deliver a noise power of:

$$Pr = KBTa \text{ (IV)}$$

k is the Boltzmann constant $= 1.38 \cdot 10^{-23}$ $T_a = 290 \text{ K (20}^\circ)$ and B = bandwidth in Hz where the power is measured.

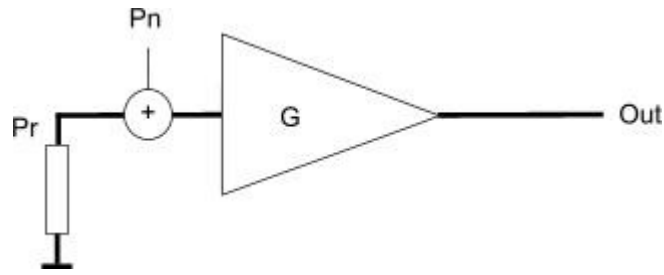

The noise factor F shows now how big P_n is compared to P_r .

$$F = \frac{(P_n + P_r)}{P_r}$$

$$P_n = P_r(F - 1) \quad (\text{V})$$

With help of formula (IV) we can express P_n as a temperature because:

$$P_n = P_r(F - 1)$$

and

$$kT_{\text{sys}}B = kT_aB(F - 1)$$

$$T_{\text{sys}} = T_a(F - 1) \quad (\text{VI})$$

This enables us to calculate P_n without knowing the bandwidth.

Example

Amplifier details: $G_{dB} = 20dB$ $NF_{dB} = 2dB$ Measurement bandwidth 3kHz.

Calculate noise power at the input and output of the amplifier and calculate noise temperature T_s

Solution:

$$NF_{[dB]} = 10 \log F$$

$$10 \log F = 2$$

$$\log F = 0,2$$

$$F = 10^{0,2} = 1,58$$

$$T_s = T_a (F - 1)$$

$$T_s = 290 * 0,58 = 169,6 \text{ K}$$

$$P_n(\text{inp}) = kBT_{\text{sys}}$$

$$P_n(\text{inp}) = 1,38 * 10^{-23} * 169,6 * 3 * 10^3 = 7,02 * 10^{-18}$$

$$P_n(\text{outp}) = 10^{(20/10)} * 7,02 * 10^{-18} = 7,02 * 10^{-16}$$

5.2 G/T ratio

Now we can set our goal. We want to have the maximum antenna gain with a minimum of noise. We can express this in the following formula:

$$G/T = \frac{\text{Gain}}{T_{\text{sys}}} \quad (\text{VII})$$

The bigger the number G/T gets the better the system is. So improving your gain will result in a bigger G/T ratio. But also lowering T_{sys} will result in a bigger G/T ratio. Now is the gain of a yagi determined by the design but the most important factor are the mechanics. A bigger array will give more gain than a small system. A lower T_{sys} is not visible from the outside but a very important factor!

If we want to convert this to dB the formula will change a bit:

$$G/T_{[\text{dB}]} = \text{Gant}_{[\text{dB}]} - 10 \log T_{\text{sys}} \quad (\text{VIII})$$

The G/T calculation enables us to directly compare 2 stations! A difference of 3dB GT between two stations means that one station receives 3dB more signal than the other station! If you calculate G/T it is a figure of merit for your station.

5.3 Factors that influence T_{sys}

The basic formula to calculate T_{sys} is a very simple one:

$$T_{\text{sys}} = T_{\text{antenna}} + T_{\text{losses}}(\text{cable, power splitter etc}) + T_{\text{receiver}} \quad (\text{IX})$$

Now let us look at the different factors separately.

5.3.1. Tantenna

As briefly discussed in chapter 3.5 the noise pick up is very important. There are 2 kinds of noise:

- Man made noise picked up from your neighbours computer (not your own off course). All the blessings from modern electronics like LCD displays, wireless car keys, RF switched street lightening, traffic lights etc. Living in a remote area might help a lot. But if you suffer from these there is not much you can do about it. Except a clean antenna pattern is needed!
- Galactic noise pick up. Your antenna will pick up noise from the sky. This was discovered already in 1932 by K.G. Jansky. He called it cosmic noise at that time and did some investigations. The most important is of course the sun but also ionized interstellar gas clouds, quasars and supernova remains. This noise varies with frequency. Cosmic noise extends from 15 MHz to 100 GHz but is dominant in the 40-250 MHz region. Below about 20 MHz atmospheric noise takes over. Raoul Pettai in his book “Noise in receiving systems” falls back to research done by Hogg and Mumford and gives the following formulas:

$$\text{maximum:} \quad T = 1450 * \lambda^2 \quad (\text{X})$$

$$\text{average:} \quad T = 100 * \lambda^{2.4} \quad (\text{XI})$$

$$\text{minimum:} \quad T = 58 * \lambda^2 \quad (\text{XII})$$

When we visualize this we get the following graphs:

Sky noise

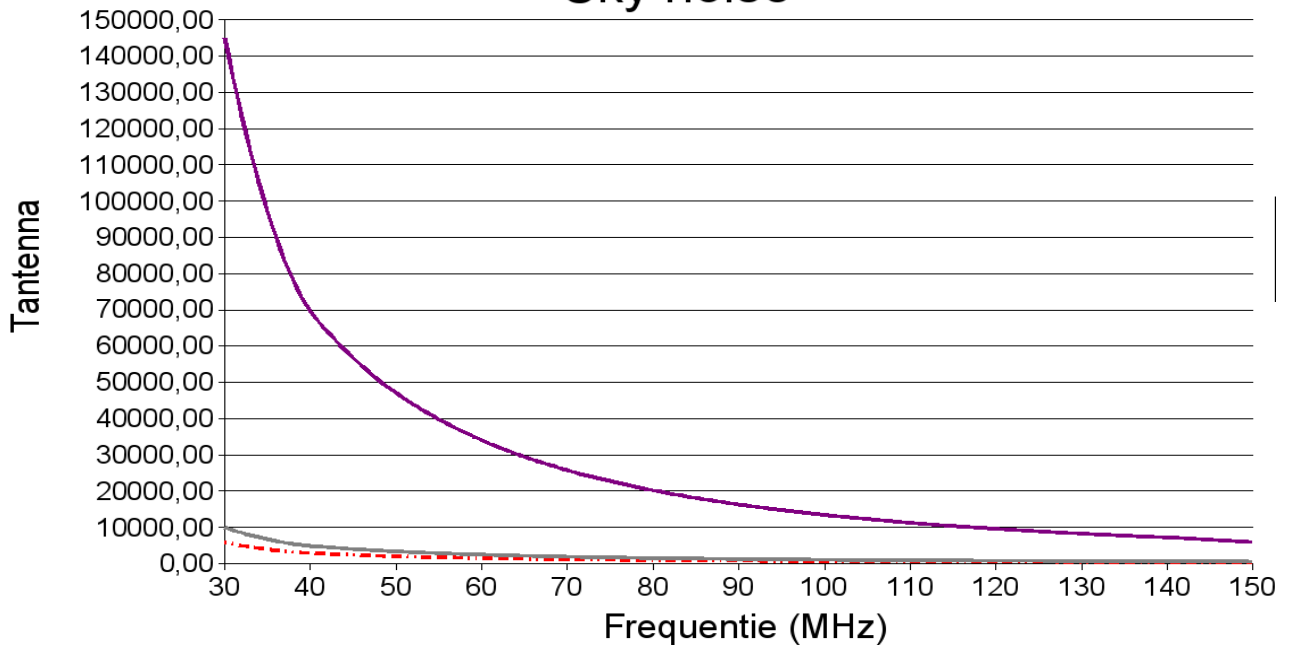

Sky noise

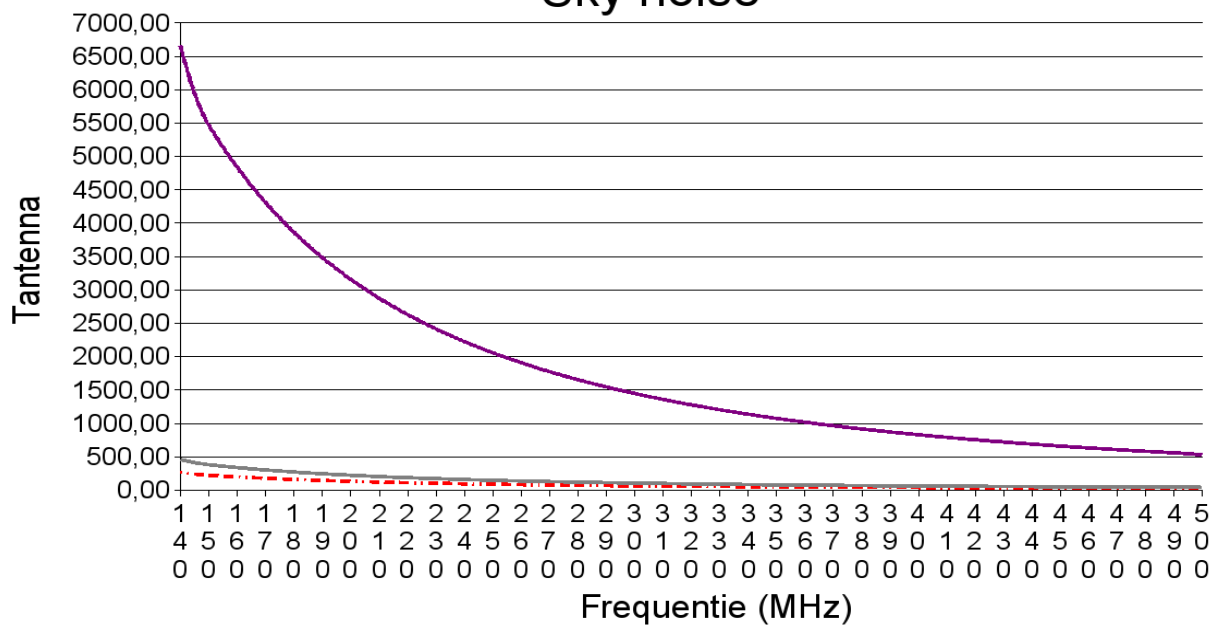

Please note the large differences in sky noise related to frequency. If we look at our own frequency band we find more accurate results in the following table.

<i>Sky noise on to the different amateur bands</i>			
<i>Frequency</i>	<i>50 MHz</i>	<i>144 MHz</i>	<i>432MHz</i>
Maximum	52200K	6293K	699K
Average	3600K	434K	48K
Minimum	2088K	251K	28K

Table 3. Sky noise on different amateur bands

5.3.2 Tlosses

The losses in front of the preamp are meant. You have to calculate the losses from one antenna to the preamp. You have to take everything into account. You will be surprised how quickly these losses add up. Let's compare three 4 yagi systems on 144 and 432 MHz and see were the differences are.

- The mediocre system consists of RG213 nicely dressed along the boom, the dipoles are folded so a coax balun is used to get a good match. All N-type connectors are used and these are mounted waterproof so no extra losses occur. A good coax relay is used and a coaxial power splitter.
- The average system consists of LDF 4-50, high quality balun from the same cable. N-type connectors are used through the system again the same coax relay and power splitter are used. The preamp box is mounted as close as possible to the dipoles.
- The high end system uses open wire feed with a high quality sleeve balun to match from the open wire to the 50 Ohm coax system

Comparison of 2m systems

Type of loss	Mediocre system 2m		Average system 2m		High end system 2m	
	type	loss dB	type	loss dB	type	loss dB
Coax / open wire	8M RG213	0,65dB	3M LDF450	0,08dB	Open wire	0,05dB
Coaxrelay	Coaxrelay	0,05dB	Coaxrelay	0,05dB	Coaxrelay	0,05dB
Power divider	Power divider	0,1dB	Power divider	0,1dB	none	0dB
Balun	RG213 1/2λ	0,1dB	LDF450 1/2λ	0,05dB	Sleeve	0,05dB
N connectors	4 pieces	0,1dB	4 pieces	0,1dB	2 pieces	0,05dB
Total loss dB		1,0dB	difference~0.6 dB	0,38dB	difference~0,2 dB	0,2dB
Losses converted in degrees K $T_{sys}=(F-1)*290$ $F=10^{dB/10}$		75K		27K		14K

Table 4. Comparison of different 2M systems

Comparison of 70cm systems

Type of loss	Mediocre system 70cm		Average system 70cm		High end system 70cm	
	type	loss dB	type	loss dB	type	loss dB
Coax / open wire	5M RG213	0,8dB	1M LDF450	0,026dB	Open wire	0,1dB
Coaxrelay	Coaxrelay	0,1dB	Coaxrelay	0,1dB	Coaxrelay	0,1dB
Power divider	Power divider	0,1dB	Power divider	0,1dB	none	0dB
Balun	RG213 1/2λ	0,2dB	LDF450 1/2λ	0,1dB	Sleeve	0,1dB
N connectors	4 pieces	0,2dB	4 pieces	0,2dB	2 pieces	0,1dB
Total loss dB		1,4dB	difference~0.9 dB	0,526dB	difference~0.13 dB	0,4dB
Losses converted in degrees K $T=(F-1)*290$ $F=10^{dB/10}$		110K		37K		28K

Table 5. Comparison of different 70cm systems

As a rule of thumb Jan, DL9KR claims that 0,1dB equals 7K As seen from the above this proves to be a good approximation.

5.3.3 Treceiver

The most important factor that will add to your Tsys in the preamp's noise figure. On the noise figure side of things there are small differences between the bands. Noise figures on the lower frequencies tend to be a little bit lower than on the higher bands. A good preamp on 144 MHz can measure a 0,3dB noise figure while on 432MHz the noise figure will be around 0,4 dB. I include the measurement results from the 2006 Würzburg EME meeting carried out by Dominique Faessler HB9BDD.

OWNER	TYPE	DEVICE 1st STAGE	STAGES	NF dB	GAIN dB	REMARKS
SM2BYA	HM	MGF1801	1	0,31	22,0	GRAPH INVALID, INCIDENTL
PA3CMC	HM		1	0,33	22,1	
PA3CSG	HM	ATF54143	1	0,38	14,0	GRAPH MISSING
EA3XU	DB6NT		1	0,4	26,0	
PE1KXH	HM	ATF34341	1	0,42	5,6	
DJ3FI	HM	MGF1801	1	0,5	25,0	
DJ3FI	HM		1	0,51	26,3	
DL3IAE	HM	MGF1302	1	0,84	17,6	
DK3EE	HM		1	0,87	16,5	
EA3DXU	HM		1	1,2	21,6	
SK4CDI	HM		1	1,5	24,7	
DK3EE	SSB EL.		1	4	22,0	GRAPH MISSING

Preamp measurement Würzburg 2006 144MHz

OWNER	TYPE	DEVICE 1st STAGE	STAGES	NF dB	GAIN dB	REMARKS
DL9KR	#1	MGF4919G	2	0,4	42,9	INCL. ADAPTOR TO 7/16
DL9KR	#3	ATF58143	2	0,43	54	INCL. ADAPTOR TO 7/16
DL9KR	#2	ATF58143	2	0,45	52,6	INCL. ADAPTOR TO 7/16
PA3CSG	HM #2	ATF54143	1	0,46	20	
DJ3FI	HM	FHX35	1	0,54	20,4	
PA3CSG	HM #1	ATF54143	1	0,56	17,4	
PA3DZL	HM	MGF1302	1	0,6	21,5	
EA3DXU	HN CAVITY		1	0,6	17,5	
DL3IAE	MICOMM	ATF54143	2	0,63	37,6	
DF1VH	MICOMM		1	0,66	20,7	
HB9Q	SSB EL.		1	0,77	19,9	
EA3DXU	HM BOX	MGF1302	2	0,82	47,4	
SK4CDI			1			NOT RATED

Preamp measurement Würzburg 2006 432MHz

These noise figures can be converted to temperatures in the same way as pointed out in formula VI

<i>Noise figure dB</i>	<i>Temperature in degrees Kelvin</i>	<i>Noise figure dB</i>	<i>Temperature in degrees Kelvin</i>
0,2dB	14K	0,7dB	51K
0,3dB	21K	0,8dB	59K
0,4dB	28K	0,9dB	67K
0,5dB	35K	1,0dB	75K
0,6dB	43K	1,1dB	84K

Table 6. Most common noise figures converted to degrees K.

Now we have all the losses converted in degrees Kelvin so what is next?

5.4 What is all this theory good for?

Well if you stayed with me this long to end up on this page it is about time that we should be doing some real calculations and sort what this article is really about. Let's calculate the G/T ratio for stations described in paragraph 5.3.2 and compare results!

<i>Type of loss</i>	<i>Mediocre system 2m</i>		<i>Average system 2m</i>		<i>High end system 2m</i>	
		<i>loss K</i>		<i>loss K</i>		<i>loss K</i>
Preamplifier	0.3dB	21K	0,3dB	21K	0.3dB	21K
Losses as in §5.3.2	cable / power splitter etc.	75K	cable / power splitter etc.	27K	cable / power splitter etc.	14K
Antenna Temperature as in § 5.3.1	minimum value	251K	minimum value	251K	minimum value	251K
Total loss dB	Tsys	347K	Tsys	299K	Tsys	286K
Antenna gain		23dBi		23dBi		23dBi
G/T ratio (VIII)		-2,4dB/K		-1,8dB/K		-1,6dB/K

Table 7. Calculation of G/T for the 2M systems in §5.3.2

Example

Antenna gain $G_{dBi} = 23dB$ $T_{sys} = 347 K$

Calculate G/T

$$G/T_{[dB]} = G_{ant_{[dB]}} - 10 \log T_{sys}$$

$$G/T = 23 - 10 \log 347$$

$$G/T = 23 - 25,40$$

$$G/T = -2,4 \text{ dB/K}$$

Please note that the differences in G/T are the same as the differences in losses shown in table 4. It is very important to realise that the gain in system improvement is the same as the improvement in the losses (cable, power splitter etc.) So if you save 0,2dB in cable losses in front of your preamp, you gain 0.2dB in G/T and in receive performance. Same goes for the preamplifier, improving your noise figure by 0,2dB will give exactly the same improvement in system performance.

Now let us do the same for the 3 systems on 70cm you'll be surprised! For comparison reasons we will leave the antenna gain the same.

<i>Type of loss</i>	<i>Mediocre system 70cm</i>		<i>Average system 70cm</i>		<i>High end system 70cm</i>	
		<i>loss K</i>		<i>loss K</i>		<i>loss K</i>
Preamplifier	0.4dB	28K	0,4dB	28K	0.4dB	28K
Losses as in §5.3.2	cable / power splitter etc.	110K	cable / power splitter etc.	37K	cable / power splitter etc.	28K
Antenna Temperature as in § 5.3.1	minimum value	28K	minimum value	28K	minimum value	28K
Total loss dB	Tsys	166K	Tsys	93K	Tsys	84K
Antenna gain		23dBi		23dBi		23dBi
G/T ratio (VIII)		0,8dB/K		3,3dB/K		3,8dB/K

Let's remember the figures from the losses as pointed out in table 5. The difference in losses between the mediocre and average system was 0,9dB. Now look at the difference in G/T ratio. it is 2.3dB! It is almost 3 times as much. An improvement of 2,5-2,7dB would mean to double the number of antennas from 4 to 8 yagis or even from 8 to 16 yagis to get the same improvement. Which would mean a dramatic increase in mechanical size, work and money! Just by doing things right! In the last decades we have seen 16 yagis stations unable to copy any smaller size station and we also did see 4 yagis stations working 4 yagi stations (and smaller) on CW random. These differences also exist in the digital modes. You can gain a lot just by doing things right!

Even the difference of the average and the high end station (0,13dB) pays with an extra of 0,4dB! A rule of thumb is that for every 0,1dB you save, you get an extra 0,3dB in G/T and also in signal to noise ratio.

Can you imagine what will happen when water gets into your system? A loss of several dB in system performance. How about open wire? Well to use the words of Jan DL9KR I now where the water is. A well designed open wire system does not suffer from SWR during wet weather.

Off course this large difference comes from the lower sky temperature. This also goes for the higher bands. In fact the sky temperature is even lower there! If you can get going on 70cm EME you should be able to get 23cm and even 13cm going as well it is more or less the same. I can personally confirm that as I used a group of 16 yagis for over 10 years on 432 MHz.

6. Sunnoise measurements

Now you know what the big “secret” of 432 MHz EME is, you want a way to verify your system! This can be done by pointing your antenna to a cold spot in the sky and afterwards to the sun. By adjusting a variable attenuator you can measure the difference between the cold sky temperature and the hot sun. To fully explain this would go beyond the goal of this paper. Please look at reference #13 for more and precise information.

You can also use VK3UM excellent software to calculate all of the above. The software can be found on the internet. See reference #7 for a place to download the software.

7. It does not work what now?

Most of the times it is working but not good enough. This is a problem! Not many of us have network analysers available. How to measure a few tenths of a dB? How to find out what losses my

coaxrelay has? I normally use a low power signal from my transceiver and a few attenuators to feed the milliwatt meter. Read the power and insert the device to be tested. Make sure your transceiver is warmed up nicely and has no power drift. This is the best way to test your system with limited resources.

Make sure your system has enough gain. A 15dB preamp and a 10dB cable loss is not good enough. Calculate your system noise figure. With the following formula:

$$F_{tot} = F1 + \frac{(F2-1)}{G1} + \frac{(F3-1)}{(G1 * G2)} + \frac{(F4-1)}{(G1 * G2 * G3)} \text{ etc. (XIII)}$$

(Please note Gain and noise are NOT in dB but as a factor)

A piece of cable can be put in the calculation as well. The cable has an attenuation of 4dB than its noise figure is also 4dB and it has a gain of -4dB

Example:

Receiver noise figure = 5dB

Preamp noise figure = 0,7dB

gain = 18 dB

Calculate noise figure and noise temperature of the complete system

Solution:

$$F_{preamp} = 10^{0,07} = 1,175$$

$$G_{preamp} = 10^{1,8} = 63,010$$

$$F_{receiver} = 10^{0,5} = 3,162$$

$$F_{tot} = 1,175 + \frac{2,162}{63,10} = 1,209$$

$$\text{Noise figure} = 10 \log 1,209 = 0,83\text{dB}$$

$$\text{Noise temperature} = 290 * 0,209 = 60,7\text{K}$$

No need to do the tedious job. There is nice software to calculate the cascaded preamplifiers. HP offers Appcad free of charge and several spreadsheets are available for free on the web. The VK3UM EME performance calculator has also an option to calculate this. I include some screen shots:

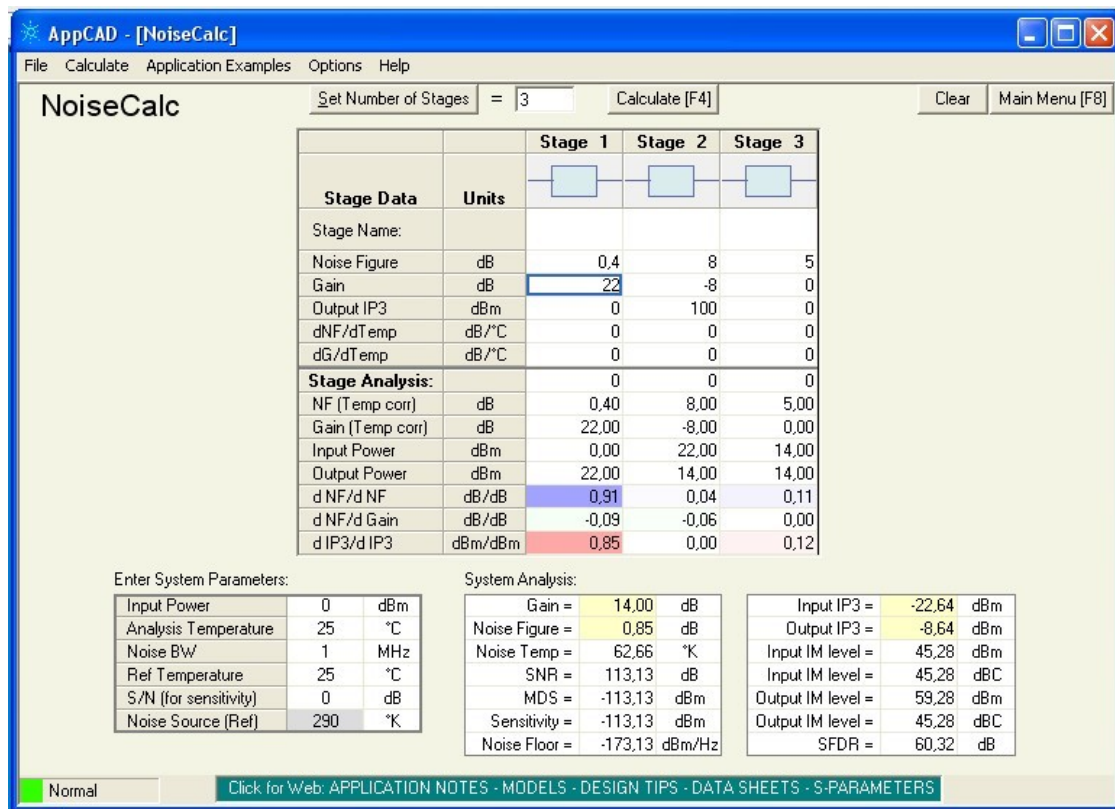

Calculation of a 3 stage system. Because of cable attenuation the total system noise figure increases up to 0,85dB.

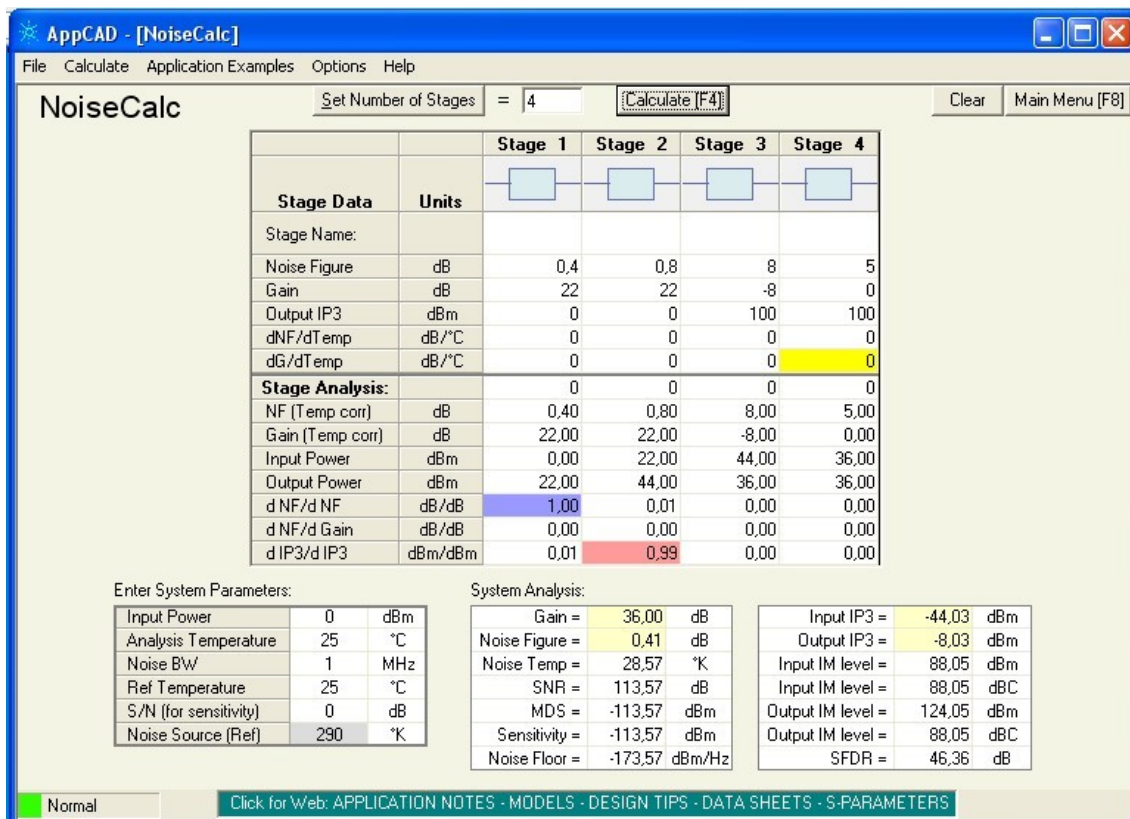

Solution of the problem in the first screen shot. An extra preamp was put in the calculation.

A double stage preamp or 2 preamps will gain you another 0,1dB in noise figure.

And thus an improvement of ~ 0,3dB

Pay attention when building your station that all connectors are fitted correctly. Make sure that there is absolutely no water coming in. Self amalgamating tape is not good enough (at least not in the Dutch climate). I learned a system from Reg Woolley, G8VHI, who was working as an antenna engineer in Germany many years ago. This never failed on me so far. First a layer of self amalgamating tape, followed by a layer of silicon sealer. While this is still soft wind a layer of medical tape around the silicon sealer. Pay attention at the end and beginning. Repeat for a second layer of silicon sealer and medical tape. Finish with silicon sealer. The medical tape will help that the silicon sealer does not loosen. A dirty job but I never had any water problems since!

8. How about a preamp on 50 MHz?

Does one need a preamp on 50 MHz? Well this should be simple! Let's compare 2 systems one with preamp the other without a preamp. A good preamp on 50 MHz should be able to obtain a noise figure of 0,25dB and as cable losses are low, a normal gain of around 20 dB should be adequate.

<i>Type of loss</i>	<i>6M system with preamp</i>		<i>6M system without preamp</i>	
		<i>loss K</i>		<i>loss K</i>
Preamplifier 0,25dB cable loss and transceiver noise figure	0.25dB	18K	none noise figure includes coax cable feeding the system and transceiver noise figure all estimated together 5dB	627K
Losses as in §5.3.2	cable / power splitter etc.	20K	cable / power splitter etc.	20K
Antenna Temperature as in § 5.3.1	minimum value	2088K	minimum value	2088K
Total loss dB	Tsys	2126K	Tsys	2735K
Antenna gain		15dBi		15dBi
G/T ratio (VIII)		-18,3dB/K		-19,4dB/K

Well the preamp is not giving a lot improvement. On the other hand if you are doing EME on this band, getting 1,1dB in antenna gain with the large dimensions on this band might be a lot of hardware involved. A preamp is not visible but does the job 1,1 dB better.

9. References

1. Raoul Pettai, Noise in receiving systems
2. Jan Bruinier, DL9KR, Some hints on low noise 432 MHz receiving systems, 1988 3rd. International EME Conference proceedings.
3. Paul Merx, PA3DSB, Ruis in ontvangstsystemen
4. http://www.k7mem.com/Electronic_Notebook/antennas/yagi_vhf_help.html
5. Leif Asbrink, SM5BSZ, <http://www.nitehawk.com/sm5bsz/antennas/cpudes01.htm>
6. Peter Sundberg, SM2CEW, internet page with the full VE7BQH G/T table
<http://www.sm2cew.com/gt.htm>
7. VK3UM software downloadable from Peter Sundberg, SM2CEW internet page
<http://www.sm2cew.com/download.htm>
8. D.C. Hogg, W.W. Mumford. The effective noise temperature of the sky. Microwave Journal

March 1960.

9. The results from the EME 2008 EME conference NF measurements, http://www.df6na.de/df6na/EME2006/nf_eme2006.htm
10. Robert Lenz, DL3WR, Rauschen in Empfangsanlagen, UKW Berichte 3 / 1975
11. Günther Hoch, DL6WU, Bestimmung der Empfindlichkeit von Empfangsanlagen mittels Sonnenrauschen, UKW Berichte 4 / 1979
12. Peter Beyer, PA3AEF, How to use open wirefeedlines.....
<http://www.mrs.bt.co.uk/dubus/9101-3.pdf>
13. Rainer Bertelsmeier, DJ9BV and Patrick Magnin, F6HYE, Performance evaluation for EME-systems. <http://www.mrs.bt.co.uk/dubus/9203-3.pdf>
14. Appcad is free of charge and offers many tools for the radio amateur. It can calculate cascaded preamps. For download see: <http://www.hp.woodshot.com/>

Special thanks go to Jean-Paul Geerets, PE1PHK, Sjaek Smeets, PE1KXH (de veurdeurlak manne) and last but not least Luis Cupido, CT1DMK.